

Design Bureau Fizelektronpribor, Ltd.

**Barrier for Level
SIUR-03V2 (VIGT.407269.025)**

Technical description and operation
manual

VIGT.407629.001-05 RE

(Rev. 10.1)



Samara, 2022

CONTENTS

1. Introduction	4
2. Purpose	5
3. Specifications	8
4. Barrier design and operating principle	9
5. Labeling and sealing	10
6. Container and packaging	11
7. General operating instructions	11
8. Safety precautions	12
9. Installation rules	12
10. Preparation and working procedure	13
11. Maintenance check	15
12. Troubleshooting	15
13. Storage rules	16
14. Transportation	16
Appendix 1. Drawing of TM and RM units of the barrier for level SIUR-03V2.5M.....	17
Appendix 2. Drawing of securing TM and RM units with horn antennas to the concrete hopper wall	18
Appendix 3. Drawing of securing TM and RM units with cylindrical emitters to the concrete hopper wall.....	19
Appendix 4. Drawing of placing TM, RM and SU units of the barrier for level SIUR-03V2.5M on the hopper	20
Appendix 5. Location of the trimmer resistor for barrier sensitivity adjustment in the synchronization unit (SU)	21
Appendix 6. Wiring diagram of the barrier for level SIUR-03V2.5M (SIUR-03V2.5 VIGT.407269.025).....	22
Appendix 7. Appearance of RM and TM units of the barrier for level SIUR-03V2.5M VIGT.407269.025 complete with horn antennas	23

1. Introduction

1.1 This technical description and the operating manual are intended to familiarize the user with the device, its operating principle, rules of installation, preparation, inspection, adjustment and maintenance in operation of the Radiowave Barrier for Level SIUR-03V2 VIGT.407629.025 (hereinafter - the barrier).

1.2 Barriers for level SIUR-03V2 correspond to Class III of protection against electric shock according to GOST 12.2.007.0-75. Barriers are designed to operate at a safe ultra-low voltage (24V), have no internal electrical circuits operating at a higher voltage.

1.3 The manufacturer reserves the right to make modifications in the barrier design and circuit that do not affect its performance without adjusting the operating and maintenance documentation.

1.4 List of conventional designations:

AN – antenna (emitter);

RM – receiver unit (receiving module);

TM – transmitter unit (transmitting module);

SU – synchronization unit;

SHF – superhigh frequencies (microwaves);

SPA – spare parts and accessories



2. Purpose

2.1 The barrier is designed to control the maximum level of tank filling with bulk and liquid materials, and can also be used to control the level of burning fuel in boilers. The barrier can be used in the conditions of high temperature and high dustiness.

2.2 Design versions of the barrier are given in Table 1.

Table 1

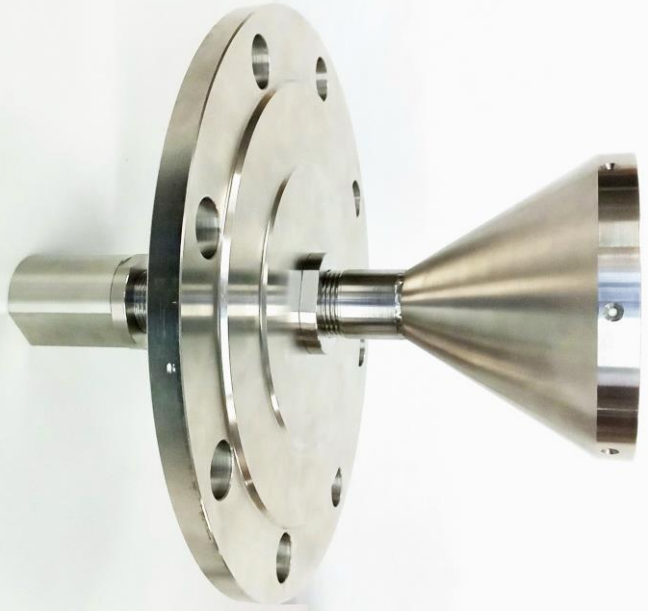
Barrier designation	Permissible temperature of unit housings	Design features
<p>Barrier for level SIUR-03V2 VIGT.407629.025</p> <p>(with an additional synchronization unit)</p> <p>SIUR-03V2.5M</p>	<p>-25...+85°C</p>	 <p>The barrier consists of two units – TM and RM – mounted on hopper walls, and an additional SU synchronization unit. TM and RM units are attached to emitters with G1 thread or using holes in the housings of units. Emitters are 120 mm long and made of AISI 321 steel. Unit housings are sealed, IP66. Cables are connected to units using the KOV1M cable leads (for an armored cable with an outer diameter of 9-17mm). The barrier features by increased sensitivity. The scope of supply includes cables for connecting TM and RM units with the SU unit.</p>

<p>Set of two horn antennas mounted on flanges VIGT.407629.101-02</p>	<p>Permissible antenna heating temperature is up to +400 °C</p>	 <p>Horn antennas, flanges (DN150, PN10), G1 couplings and G1 locking nuts are made of AISI 321 steel. Horn antennas are connected to the barrier emitters using a coupling (threaded fitting) with straight pipe thread 1" and are fixed using locking nuts (locknuts).</p>
<p>Set of two emitter pipes VIGT.407629.101-03</p>	<p>Permissible heating temperature of pipe ends is up to +400 °C</p>	 <p>A set of two 370 mm long probe pipes made with a ceramic plug at the end. Pipes are connected to the barrier emitters using a coupling (threaded fitting) with straight pipe thread 1" (G1), the pipe material is AISI 321 steel. The peculiarity of this version: G1 thread is made on the 250 mm pipe section to enable pipe securing in the flange.</p>

Barriers for level SIUR-03V2.5M consist of three units: receiving (RM) and transmitting (TM) units, which are installed on the walls of the hopper (tank) and the synchronization unit (SU). The synchronization unit provides increased selectivity of the received signal, and serves as a power source for RM and TM units.

The probing microwave signal input into the hopper is carried out through holes in its walls, which should be made at the level to be monitored. The presence of the material at the specified level is determined by the attenuation of the signal as it propagates from the transmitting module to the receiving one. Modules are equipped with antennas (emitters) made as pipes with G1 thread (straight pipe thread 1" according to GOST 6357-81). Moreover, pipes are filled with PTFE (F4) so that these units can operate at pressures up to 1.0 MPa. Mounting using flanges with the specified thread inside is allowed.

If hopper walls are made of a non-metallic material (concrete, brick), it is also possible to install barriers without making through holes in the wall. In this case, the microwave probing signal attenuation in the walls should not exceed the barrier sensitivity threshold. A decision as to using the barrier without making holes can be made after experimental verification of the microwave signal attenuation level in actual operating conditions. Barrier sensitivity can be increased using horn antennas that ensure the alignment of emitters and reduce their beamwidth.

For reliable operation of the barrier when filling the hopper, the probing signal power in the controlled material must be attenuated by 3...5 times (or more). It was experimentally established that the microwave signal power is weakened by at least 10 times in a layer of cement, ore, crushed stone, sand with a thickness of over 30 cm. At the same time, a layer of material of small thickness, e.g. up to 5 cm, attenuates microwaves by less than 3 times. This feature makes it possible to use barriers to control materials that can stick to the sensor and hopper walls. It is important to note that high ambient temperatures inside the tank and the presence of dust do not affect the propagation of microwaves. The design of barriers SIUR-03V is protected by the patent RU 2631519.

Example of the barrier designation used when ordering and in the technical documentation for other products:

"Barrier for Level SIUR-03V2 VIGT.407629.025".

3. Specifications

Main specifications of SIUR-03V2 VIGT.407629.025 are given in Table 2.

Serial No.	Parameter	Table 2 Value
1	Sensitivity (maximum permissible attenuation of the microwave probing signal on its propagation path from the transmitting module to the receiving module), dB	90
1.1	Threshold attenuation level set by the manufacturer that corresponds to tank filling, dB	92
1.2	Threshold attenuation level set by the manufacturer that corresponds to the empty tank, dB	88
2	Output voltage, V - If the tank is not filled at a controlled level (the microwave signal passes through the tank with a small attenuation) at a power supply voltage of 24V), min - When the tank is filled at a controlled level, max <i>Note: The output switch is based on a p-type field-effect transistor</i>	23 1
3	Output transistor switch delay time, sec	3
4	Ambient temperature at the RM, TM and SU unit installation site (permissible temperature of unit housings during operation), °C	-25 ... +85
5	Maximum permissible heating temperature of the external (emitting) end of the antennas (provided that Paragraph 4 is met), °C,	+400
6	Size of holes in tank walls, mm, min	Ø35
7	Operating wavelength range of the probing microwave signal, cm	3
8	Average probing signal power, max, mW	50
9	Electrical load of the output transistor switch, max, mA	150
10	Supply voltage (U _{sup}) of the barrier (DC source), V - nominal - maximum allowable - minimum allowable	+24 +27 +20
11	Current consumption at a supply voltage of 24V, max, mA - RM unit - TM unit - SU unit (total current, excluding current consumed by external load)	40 400 500
12	Overall dimensions of RM and TM units (without emitters and without cable glands), mm	110x110x90
13	Overall dimensions of the SU unit (without cable glands), mm	180x110x90
14	Overall dimensions of emitters, mm - horn (VIGT.407629.101-02) - cylindrical (VIGT.407629.101-03)	Ø135, L=280 Ø34, L=370
15	IP rating of barrier units from dust and moisture ingress according to GOST 14254-2015	IP66
16	Mass of electronic units, kg - TM unit - RM unit - SU unit	1.5 1.5 1.8
17	Guaranteed service life, months	24

4. Barrier design and operating principle

4.1 The barrier is a device for SHF signal (microwave signal) receiving and transmission consisting of the following units:

- Transmitting unit (TM - transmitting module)
- Receiving unit (RM - receiving module)
- Synchronization unit (SU).

4.2 Operating principle of the barrier is as follows.

Transmitting and receiving units with antennas are installed on the opposite walls of the tank at a controlled level. Antennas emit and receive radio waves (microwaves) through the tank walls.

The transmitter, through an antenna connected to it, emits a microwave signal inside the tank, which enters the receiver through the second antenna, where it is converted into an information signal.

The criterion for the presence or absence of bulk material at a controlled level in the tank is the degree of the radiated radio signal energy absorption on the way from the transmitting antenna to the receiving one.

4.3 The TM transmitter unit contains a microwave modulator and a voltage stabilizer with an output voltage of +12V. A microwave generator based on the bulk NC diode generates radio pulses with a peak pulse power of 100 MW with a carrier frequency in the 3-centimeter wavelength range (about 10 GHz).

Two LEDs are installed in the transmitter unit to monitor its operation. One LED is connected to the +24V input power supply circuit and lights up when the power supply voltage is applied. The second LED is intended for monitoring the microwave generator performance.

4.4 The RM receiver unit in all types of barriers is a microwave detection receiver, which includes a microwave detector, a signal amplifier with a frequency of 60 – 80 kHz and a supply voltage stabilizer with an output voltage of +12V.

The SU synchronization unit includes:

- Sync generator for TM and RM units
- Synchronous detector
- Comparator that determines the output switch triggering threshold
- Integrator that provides a 3 sec turn-on delay
- Output transistor switch based on a *p*-type field-effect transistor with the source connected to a +24V bus

Barrier sensitivity can be adjusted using a trimmer resistor located in the SU unit (Appendix 5).

4.4.1 Operating principle of the receiver is as follows.

When bulk material is absent at a controlled level, the microwave signal passes from the transmitter to the receiver with low attenuation, while the output transistor switch of the **SU** unit is open and the voltage at its output is +24V.

When the material is loaded into the tank, it gradually blocks the microwave beam. The amplitude of the received signal and the output transistor switch of the SU unit is locked.

Gain adjustment (i.e. receiver sensitivity) is made by a trimmer resistor located on the lower board under the SU unit cover. It is adjusted using a screwdriver insertion hole provided in the upper board (Appendix 5). At the factory setting, the resistor is placed in a position corresponding to the consistent microwave signal reception with the maximum possible signal attenuation between the antennas of the TM and RM units.

A turn-on and turn-off delay of about 3 seconds is provided in the receiver to eliminate false activation.

Note. It should be noted that this delay reduces the turn-on frequency of the electric motor controlling the tank loading.

4.4.2 There are two LEDs in the synchronization unit (SU) provided for barrier operation monitoring (Appendix 5).

One LED connected to the +24V input power supply circuit lights up when the power supply voltage is applied. The second LED is a two-color one. When sufficient microwave signal strength is detected at the receiver input, this LED starts to turn green. The higher the microwave signal strength, the brighter the LED glowing. After a set delay time (3 sec), when the output stage is triggered, the second element (red) of this LED turns on. As a result, the LED glow turns yellow. When the microwave beam is blocked, the brightness of the green element of this LED begins to decrease until it completely disappears. When the intensity of the microwave signal decreases to a threshold value, the output transistor switch is turned off with a delay of 3 seconds and the LED switches off completely.

4.4.3 As the barrier operation experience shows, it is not necessary to change the factory settings when barriers are installed on the tank. LEDs are quite enough to monitor the operation. Nevertheless, the barrier has an option of monitoring the microwave signal attenuation by the synchronous detector output voltage. This voltage can be monitored using a voltmeter connected to "COM" and "CTRL" terminals in the SU synchronization unit (Appendix 5).

A DC voltmeter (multimeter in voltage measurement mode) is used for monitoring. The negative lead of the voltmeter is connected to the "COM" terminal, and the positive lead is connected to the "CTRL" terminal. When the tank is not filled, the device must indicate signal strength of at least 7.2V, and when the tank is filled this indication must not exceed 2V.

4.5 Designs of the RM and TM units are identical in layout and in overall and connecting dimensions.

The supporting structure of each unit is a housing closed with a cover. The housing contains:

- SHF generator (in the TM unit)
- SHF detector (in the RM unit)
- Printed circuit boards of low-frequency devices.

The unit cover is attached to the housing with screws with rubber gaskets used for sealing.

4.6 The overall dimensions of the barrier units are shown in Appendix 1. The figure in Appendix 4 shows the barrier installation on a reinforced concrete hopper. Appendix 6 shows the barrier wiring diagram.

5. Labeling and sealing

5.1 The following signs and inscriptions are applied on the receiver and transmitter covers: name and type of the device, type of the unit (RM, TM or SU), serial number according to the manufacturer's numbering system, year of manufacture.

5.2 Seals may be installed inside the RM, TM and SU units to prevent unauthorized opening of the device.

6. Container and packaging

6.1 Containers and packaging are intended for barrier storage and transportation and ensure its safety during transportation and storage.

6.2 Barrier units, parts and components included in the delivery set, spare parts and operating documentation shall be packed in containers.

6.3 Operating documentation is wrapped in plastic wrap.

6.4 The scope of supply shall include a packing list in the transport container indicating the name and quantity of the products delivered in it.

7. General operating instructions

7.1 Unpacking rules.

7.1.1 Upon receipt of the container with the barrier, its external inspection is carried out together with the person responsible for transportation. It is necessary to make sure that the container is completely safe.

In case of any damage to the container, a relevant report shall be drawn up and signed by persons responsible for acceptance and transportation, sealed and sent to the carrier.

7.1.2 In the cold season, boxes shall be unpacked only after keeping them in a warm room with a temperature not lower than +18 ... 20 °C.

7.1.3 After unpacking, the contents of packages shall be checked with the inventory in the packing lists. The name, designation, serial number and quantity of products shall match the entries made in the packing lists.

7.2 Inspection rules.

7.2.1 During the external inspection of the products, check the integrity of the barrier unit housings, the safety and absence of their damage. The product must be free from any scratches, cracks, dents, traces of corrosion and other defects that can be detected during external inspection.

7.2.2 All defects and non-conformities detected during unpacking and external inspection and completeness verification are reported in a damage claim signed by persons responsible for barrier acceptance, approved by the head of the customer plant and sent to the manufacturer.

7.3 Connection rules.

7.3.1 The barrier must be powered from a general purpose stabilized DC power supply with an output voltage of 23...25V (maximum permissible power supply indicators are 20 ... 27V).

7.3.2 The galvanic isolation of the power supply output circuits from the 220V network must be at least 500V.

7.3.3 In order to prevent the barrier housing from exposure to mains voltage in case of emergency (in case of a power supply failure), it is recommended to connect the "-24V" power supply terminal with the grounding bus directly in the control cabinet, and install the electronic unit housings on metal brackets connected to the grounding bus.

7.3.4 The length of cables powering the SU unit and the cross-section of their conductors are selected so that the voltage drop on the conductors at a maximum current of 600mA does not lead to a decrease in the operating voltage below the limit level of 20V. The barrier own power consumption (excluding the power consumption of the actuator) does not exceed 15W.

TM and RM units are connected to the SU unit with special cables included in the scope of supply (Appendix 4).

7.3.5 Electric relays or other electrical devices rated for an operating voltage of 24V and a consumption current of up to 150mA can be used as an information receiver (actuator).

7.3.6 When several barriers are installed close to each other, the microwave signal of one barrier must be prevented from entering the receiver from another set. For this purpose, it is recommended to place them when installing barriers so that the distance between the ends of transmitter probes at one barrier and the receiver of the other one is as large as possible.

To detect the effect of transmitter radiation in one set on the receiver from another set, turn off the transmitter of the second set and make sure that transmitter radiation in the first set does not activate the receiver of the second set. Then repeat the same procedure for the receiver of the first set.

The time of barrier readiness for operation after the supply voltage is applied does not exceed 2 minutes.

8. Safety precautions

8.1 It is forbidden to operate the barrier without the external 24 V power supply grounding.

8.2 As an additional safety measure, it is recommended to connect the "-24V" power supply terminal to the ground bus.

8.3 It is forbidden to operate the barrier with its covers removed.

8.4 Barrier installation (dismantling), operation, maintenance and repair shall be performed only by persons who have read and understood this technical description and operating instructions and completed an induction on safety when working with electrical installations and electronic equipment.

8.5 All types of maintenance, repair and installation related to soldering of electrical and radio elements, desoldering of cables, replacement of failed elements, elimination of wire breakage, etc., as well as barrier dismantling shall be carried out only with the barrier disconnected from the power source.

8.6 It is not allowed to operate the barrier with poorly secured supply wires and removed covers.

9. Installation rules

9.1 Barrier installation and connection shall be performed with the strict observance of safety rules specified in Section 8 of this manual and in the regulatory and technical documents in force at the customer plant.

9.2 A barrier that has passed technical inspection in accordance with the procedure described in Section 11 is supplied for installation at the facility.

9.3 At the first stage, it is necessary to select the installation locations of the transmitter and receiver electronic units taking into account the permissible operating conditions. Places for the installation and securing of barrier components shall be prepared in accordance with the overall and installation dimensions of the units.

9.4 Depending on the version, barrier antennas are installed either directly in holes made in the tank walls or near these holes.

CAUTION! When installing antennas of any barrier version, it is necessary to ensure the same polarity of the transmitting and receiving antennas. When installing the transmitting and receiving units, their housings shall be turned around the axis of antennas so that their similar axes are parallel (connectors/cable glands will be directed in one direction or in opposite directions).

9.5 Barrier antennas can be installed without direct contact with the tank walls. The maximum distance of the antenna radiating surface from the wall is determined by the size of the hole in the wall. The larger the hole, the greater the distance for moving away the antenna aperture without any losses in the microwave signal strength. Hole sizes in all cases must be no less than the waveguide cross-sectional dimensions. For circular waveguides, the hole diameter must be at least Ø35mm, and the antenna must be positioned relative to the hole so that the hole edges do not overlap the antenna radiating aperture.

9.6 Lay cables between the barrier units and the power supply and the actuator (relay) and connect the barrier in accordance with the wiring diagram given in Appendices 4 or 6 and according to the layout drawing of the customer plant.

10. Preparation and working procedure

10.1 The barrier is serviced by an operator familiar with the operation of electronic equipment, who has read and understood this technical description and operating instructions, and completed an induction on safety and radio and electrical equipment operation.

10.2 The barriers operate in one mode – continuous remote monitoring of the maximum tank filling level.

10.3 Preparation for work is carried out in the following order:

10.3.1 Remove the covers of the TM, RM and SU units.

10.3.2 Make sure that connections between the units are correct and reliable according to the wiring diagram (Appendix 6), as well as connections with the power supply and the actuator (relay).

10.3.3 Before connecting the barrier to the power source, check the set voltage on the power source with a voltmeter. It must not exceed +23 ... 25V.

10.4 Turn on the power supply. Power supply and generator operation LEDs must light up on the upper board of the generator. The power supply LED must light up on the top board of the receiver. After that, close the covers of the RM and TM units.

10.5 When switching on for the first time, make sure that the barrier activation level (sensitivity) set by the manufacturer corresponds to the application conditions.

A prerequisite for performing this operation is the absence of the loaded material and any other objects along the beam between the transmitter and receiver antennas.

Note. The beam width is at least 30 degrees, so it is not necessary to achieve the exact placement of the antennas along one line.

Sensitivity is checked when all placement and securing operations are completed for the barrier units. If the receiver receives the transmitter signal, then the green/yellow indicator lights up in the SU unit. Moreover, when a microwave signal appears, the LED first begins to glow green, and then, when the threshold level is reached, after 3 seconds, its glow turns yellow (green+red).

When the microwave beam is blocked, the brightness of the green element of this the decreases to a threshold value, the output transistor switch is turned off with a 3-sec delay, and the LED goes out completely.

When setting up the barrier, a DC voltmeter connected to the SU unit test terminal must be used as specified in Section 4.4.3. This will allow you to more accurately control the strength of the received microwave signal and the activation threshold.

In the absence of a microwave signal, the voltage at the test terminal must not exceed 1V.

As the microwave signal increases, the voltage at the test terminal increases. Simultaneously with the increase in voltage, the brightness of the green LED element increases. The barrier is activated (the red LED element lights up) at a voltage at the test terminal of about 7.2 V.

With a further increase in the microwave signal, the voltage increases to a saturation voltage equal to 10.6V.

When the microwave signal intensity decreases, the voltage at the test terminal drops. At the same time, the brightness of the green LED element decreases.

The output stage is turned off (the red LED element is also turned off) at a voltage less than 3.1V.

Thus, the threshold turn-on voltage of the output signal is 7.2V, and the threshold turn-off voltage is 3.1V.

Note. At the manufacturer plant, the barrier is adjusted to the maximum possible sensitivity to ensure its operation through the tank walls. Therefore, the voltage at the test terminal may be negative when the barrier is operated without any obstacles between the antennas of the TM and RM units. This indicates an unacceptably high strength of the microwave signal.

Note. The barrier sensitivity level set by the manufacturer is optimal in most applications. Therefore, before adjusting the sensitivity, it is necessary to make sure that it is necessary, and check that the requirements of Sections 9.4 and 10.5 are met.

10.6 If the sensitivity is too high (test voltage is always greater than 7.2V), then it is necessary to reduce the sensitivity. Too high sensitivity will manifest itself in the fact that when the tank is filled, the barrier will turn off the output relay with an excessively long delay or will not operate at all. If the sensitivity is too high, radio signals re-reflected from the tank walls are also received along with radio signals propagating along the line between the antennas.

If the sensitivity is insufficient (test voltage is always less than 7.2V when the tank is not filled), then it is necessary to increase the sensitivity using a trimmer resistor (Appendix 5).

If an increase in the sensitivity using a trimmer resistor does not lead to an increase in the voltage at the test terminal, this means that the signal attenuation by the tank wall (or for other reasons) is unacceptably high.

In this case, it is necessary to make holes in the concrete wall and use cylindrical antennas with plugs (Appendix 3).

10.7 To adjust the sensitivity, adjust the trimmer resistor installed inside the SU unit (Appendix 5). To do this, use a small screwdriver to turn the resistor terminal: clockwise rotation increases the sensitivity, counterclockwise rotation decreases it.

To eliminate receiving the microwave signal re-reflected from the tank walls, the sensitivity must not be set too high, but at the same time, it must be sufficient for stable and reliable reception of the signal that passed along the line between the antennas. To achieve the optimal sensitivity

value, it is necessary to rotate the resistor terminal to select a position at which the test voltage is greater than 7.2V.

11. Maintenance check

The list of basic maintenance checks is given in Table 3.

Table 3

Check types	Technical requirements
1. Grounding check with an ohmmeter	The standard transient resistance of wires and grounding terminals determined by regulatory documents in force at the customer plant, and Electrical Installation Code
2. Barrier current consumption check	The value of the current consumed by the barrier must be within 400...600mA.
3. Supply voltage check	The DC voltage at the power supply output terminals when the barrier is connected must be within 23 ...25V.

12. Troubleshooting

12.1 Any malfunctions detected must be eliminated only when the barrier is disconnected from the power supply.

12.2 When replacing failed circuit elements, strictly follow the instructions of Section 13 of this manual.

12.3 The replacement of the failed elements and the inspection of the barrier after the elimination of the detected malfunction shall be carried out by a specialist in its maintenance.

12.4 The list of potential malfunctions is given in Table 4.

Table 4

Description of malfunction, external manifestations and additional signs	Probable cause	Method of elimination
1. Power LEDs do not light up when the barrier is energized. Additional signs: - Supply voltage at the input of the power supply wire of the communication line is 24V - There is no current in the power supply circuit of one or both units.	Broken power wire, blown fuse	Persons responsible for the operation shall eliminate the malfunction in accordance with the applicable rules.
2. Power LEDs do not light up when the barrier is energized. Additional signs: - Current in the power supply circuit is more than (600mA).	Short circuit in the barrier power supply circuit	Persons responsible for the operation shall eliminate the malfunction in accordance with the applicable rules.

3. When the tank is not filled, the barrier gives information about its filling above the control level (i.e. there is no microwave signal reception).	Malfunction in the power line. Incorrectly installed units, e.g. the TM and RM units are turned relative to each other by 90° or their antennas are not directed at each other	Make sure that power supply circuits operate properly and that the installation is correct. Dismantle the TM and RM units from the installation places and check them for compliance with Paragraph 4 of Table 3.
4. When the tank is full, the barrier gives information about the absence of filling (i.e. the received microwave signal has a high level).	Incorrectly installed units: a) The gap between the antennas and holes in the hopper walls is too large, while the microwave signal between the units propagates outside the hopper. b) The microwave signal is re-reflected from the inner walls of the hopper and does not propagate in a straight line between them due to the incorrectly oriented antennas with the excessive RM unit sensitivity.	Make sure that the TM and RM units are installed correctly. Make sure that power supply lines of the barrier are properly grounded. Dismantle the TM and RM units from the installation places and check them for compliance with Paragraph 4 of Table 3. Adjust the sensitivity in accordance with Section 10.6.

13. Storage rules

Barrier storage and transportation conditions are in accordance with GOST 15150-69 for Group 3 and Group 5, respectively.

13.1 Depending on the period, barrier components the manufacturer's package can be stored in hard-wall heated or unheated premises with the air free from acid vapors, alkalis and other harmful substances that cause corrosion.

13.2 The barrier storage period in the manufacturer's package is one year. At the same time, when stored in hard-wall unheated premises at a temperature of +50...-40°C and relative humidity up to 80% at a temperature of +25°C, the storage period is 3 months.

The rest of the time it shall be stored in the conditions of hard-wall heated rooms at a temperature of +5...+30°C and relative humidity up to 65% at a temperature of +25 °C.

14. Transportation

14.1 The barrier packed in a transport container can be transported by any means of transport in closed vehicles for any distance.

14.2 Boxes with packed barrier parts shall be secured on vehicles so that to eliminate the risk of box displacement or collision. Transportation is carried out in compliance with all precautions. It is prohibited to throw and turn over boxes with packaging.

Appendix 1. Drawing of TM and RM units of the barrier for level SIUR-03V2.5M

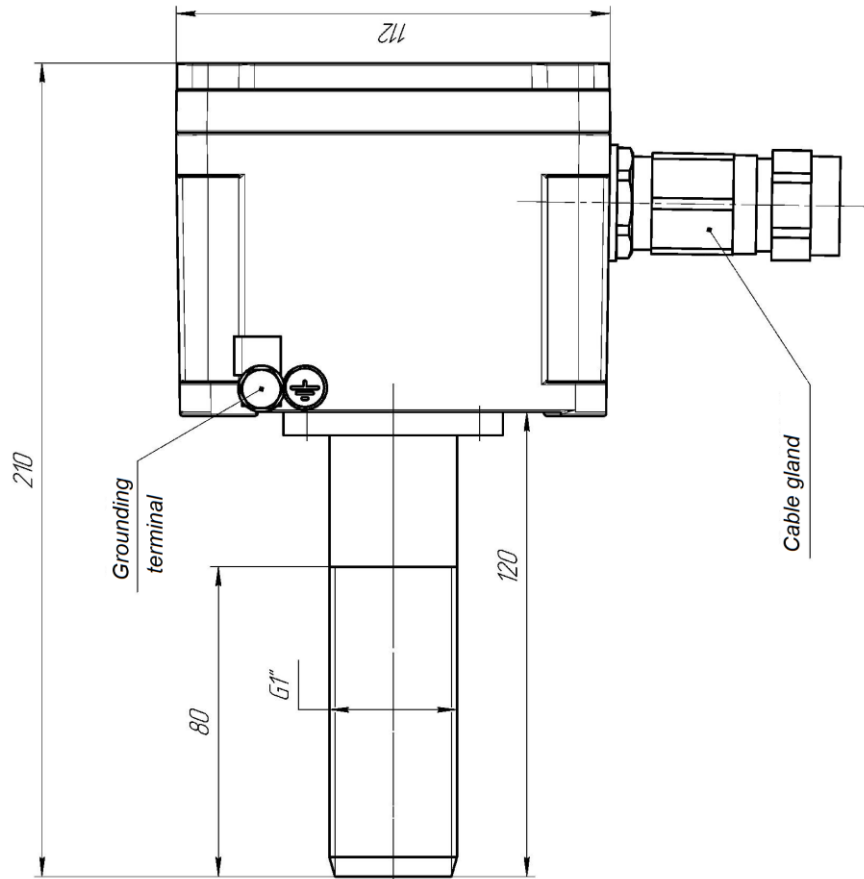

Appendix 2. Drawing of securing TM and RM units with horn antennas to the concrete hopper wall

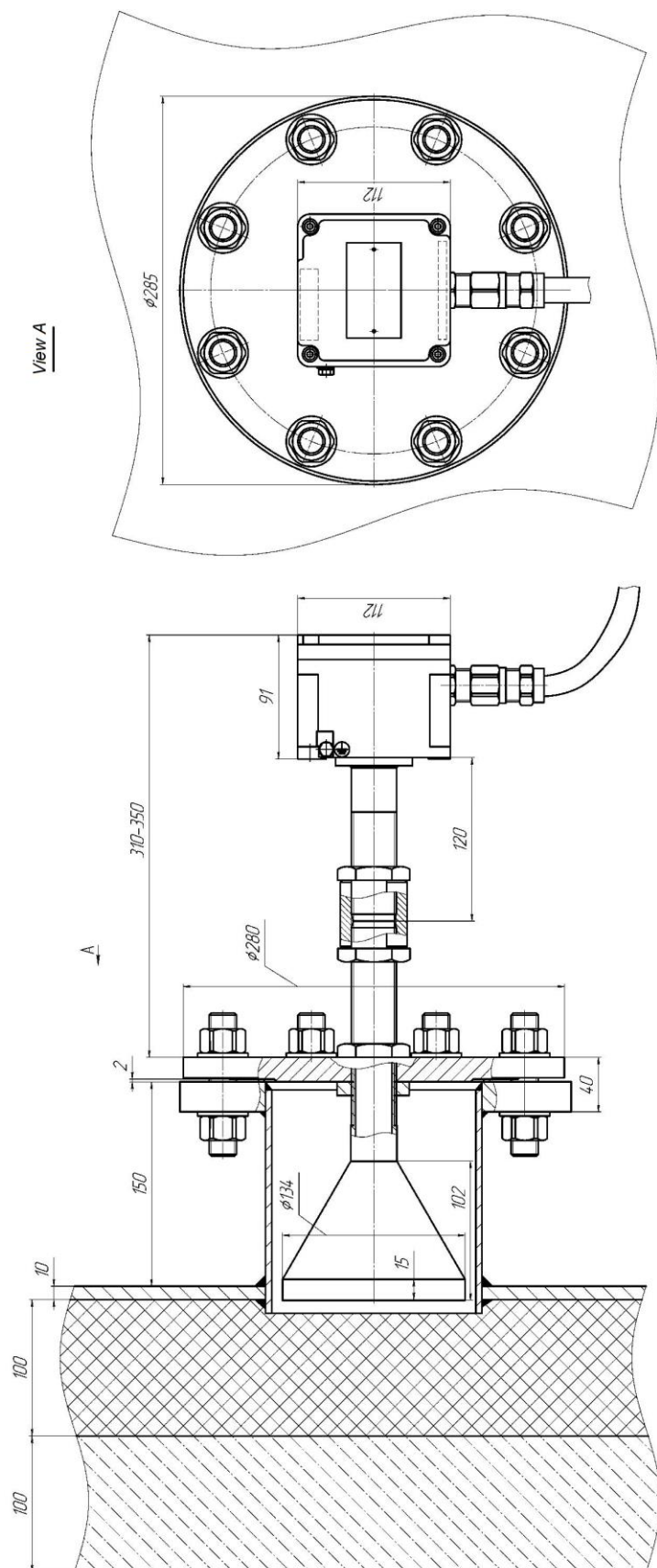

Appendix 3. Drawing of securing TM and RM units with cylindrical emitters to the concrete hopper wall

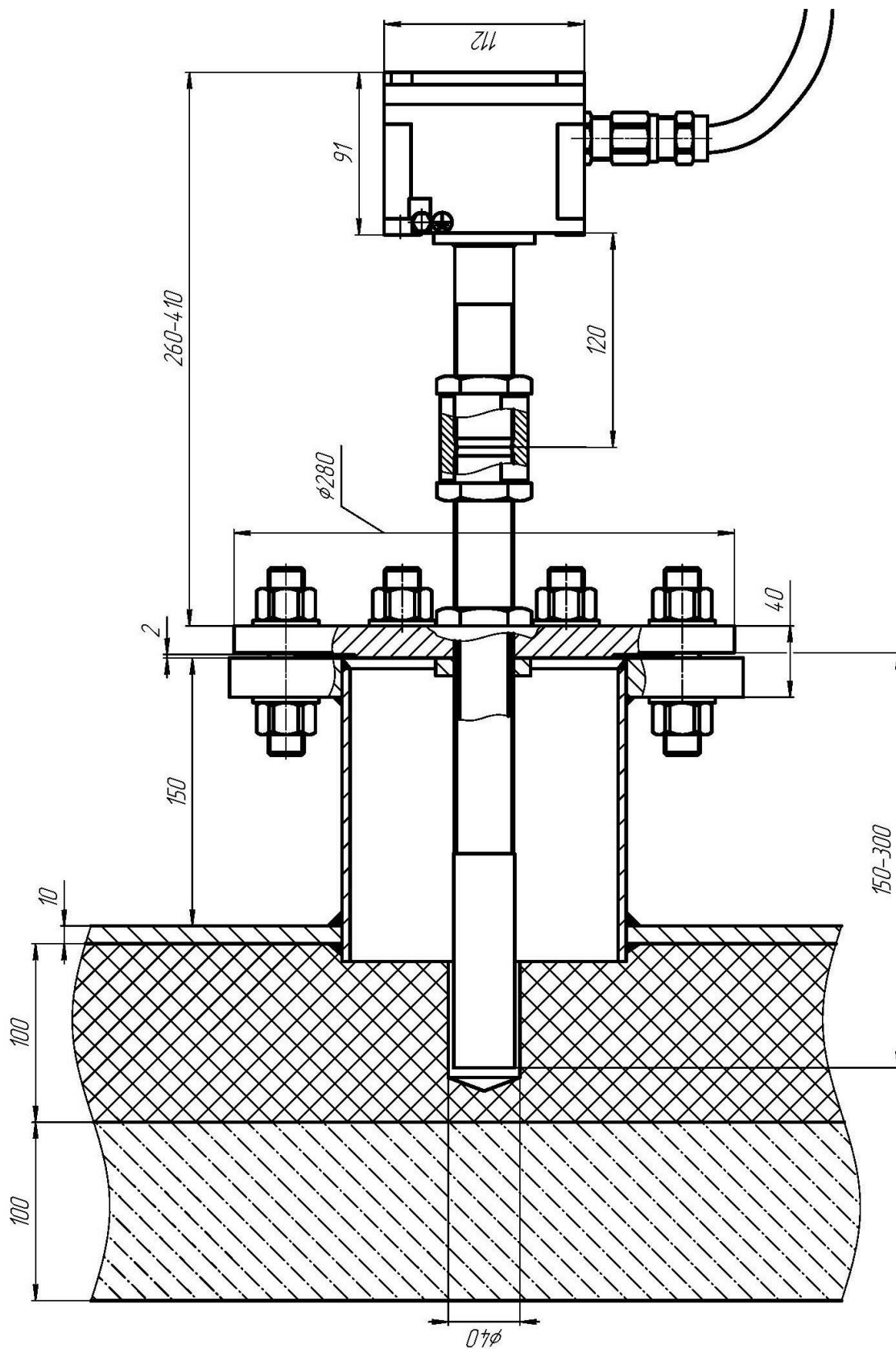

Appendix 4. Drawing of placing TM, RM and SU units of the barrier for level SIUR-03V2.5M on the hopper

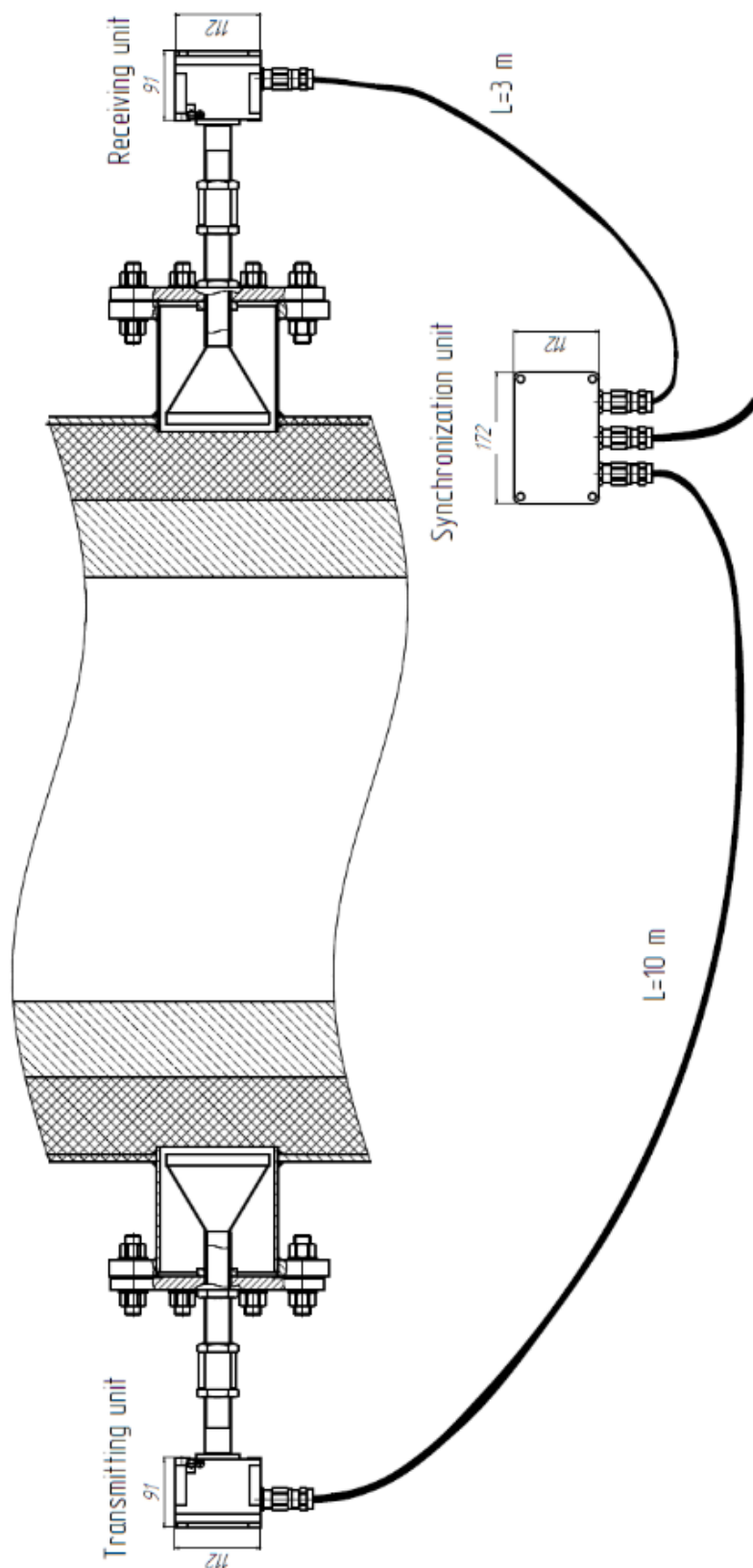

Appendix 5. Location of the trimmer resistor for barrier sensitivity adjustment in the synchronization unit (SU)

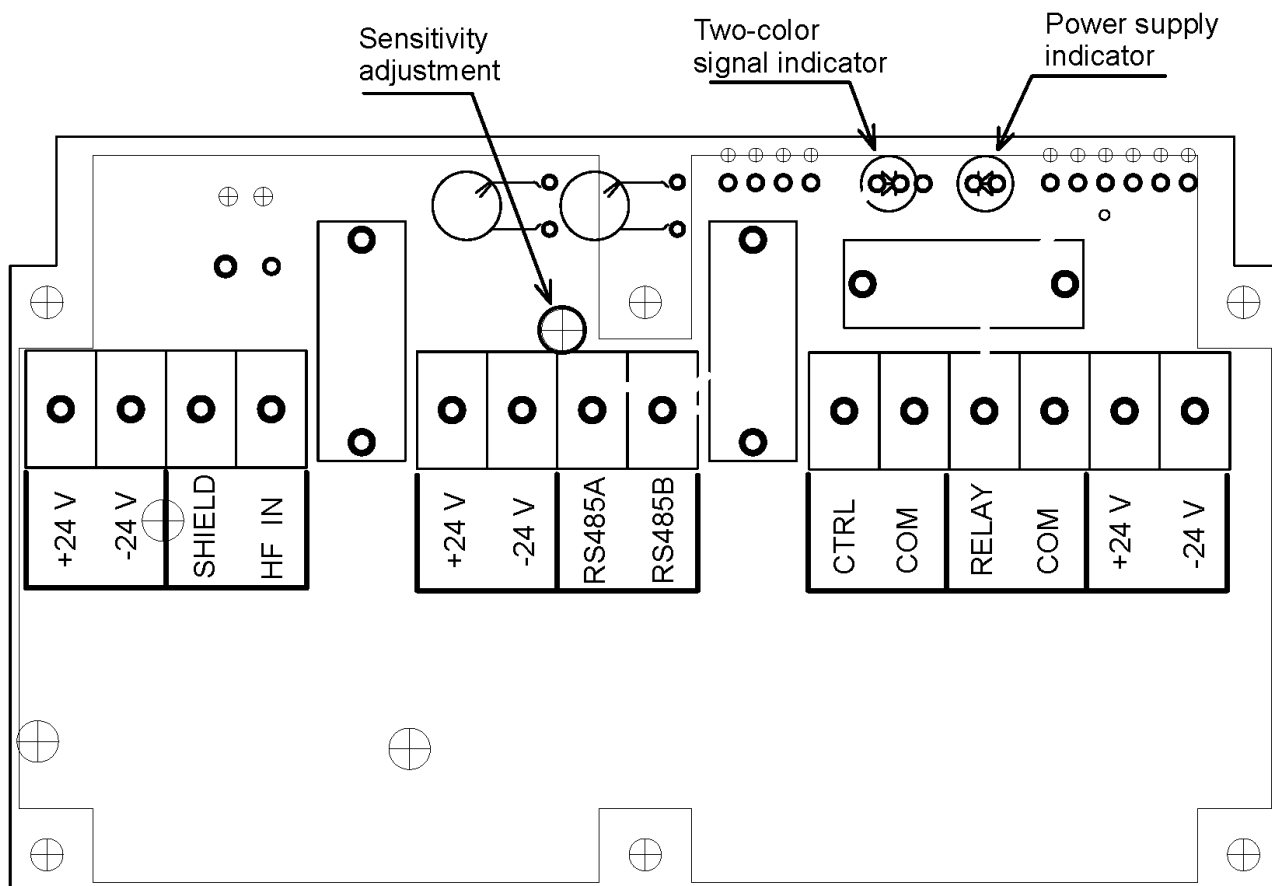

Appendix 6. Wiring diagram of the barrier for level SIUR-03V2.5M (SIUR-03V2.5 VIGT.407269.025)

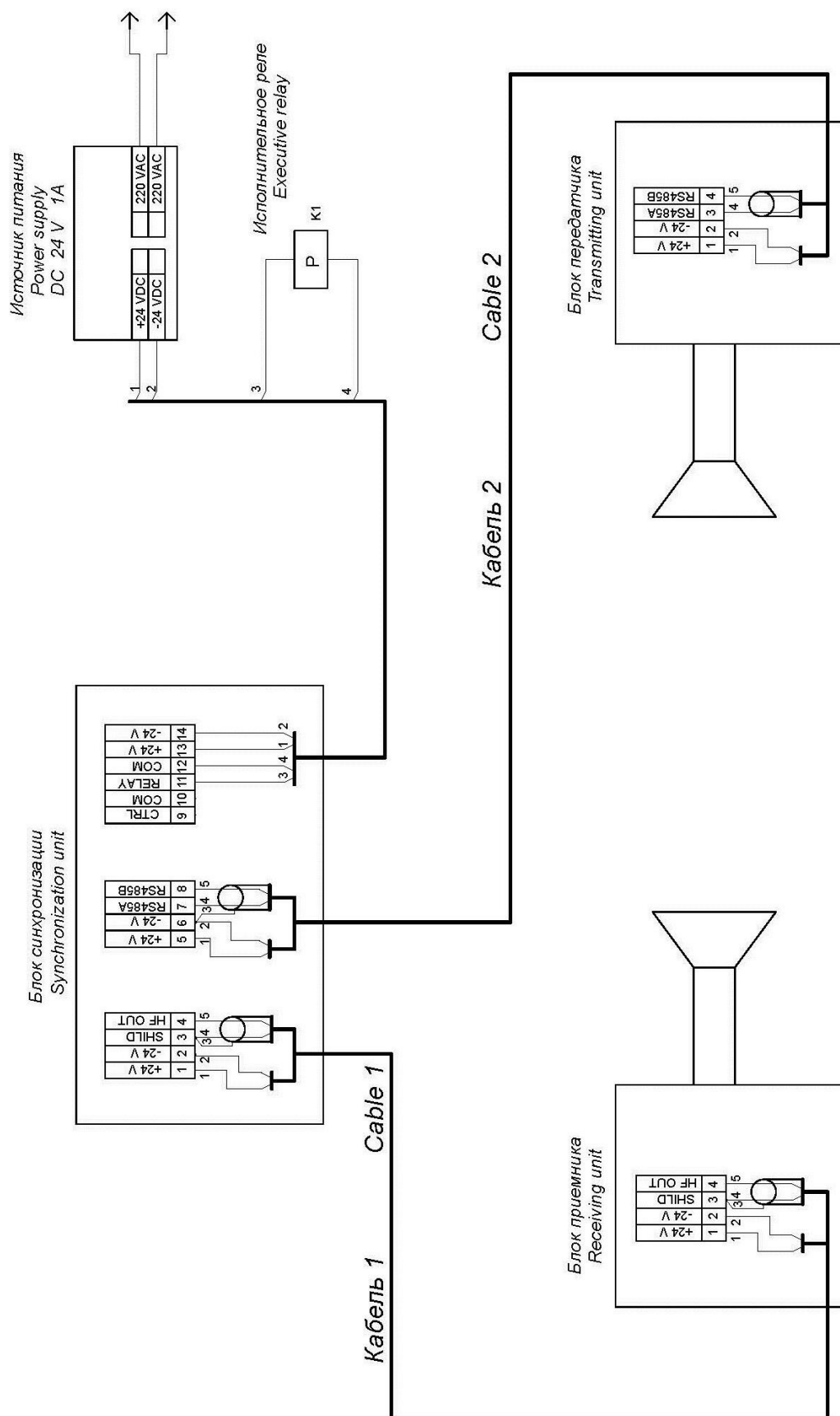

**Appendix 7. Appearance of RM and TM units of the barrier for level SIUR-03V2.5M
VIGT.407269.025 complete with horn antennas**

